

版次	变更内容	审核	日期

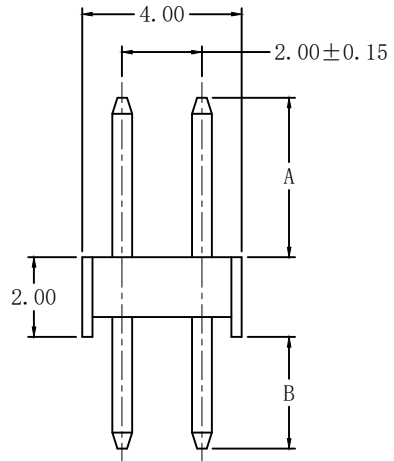
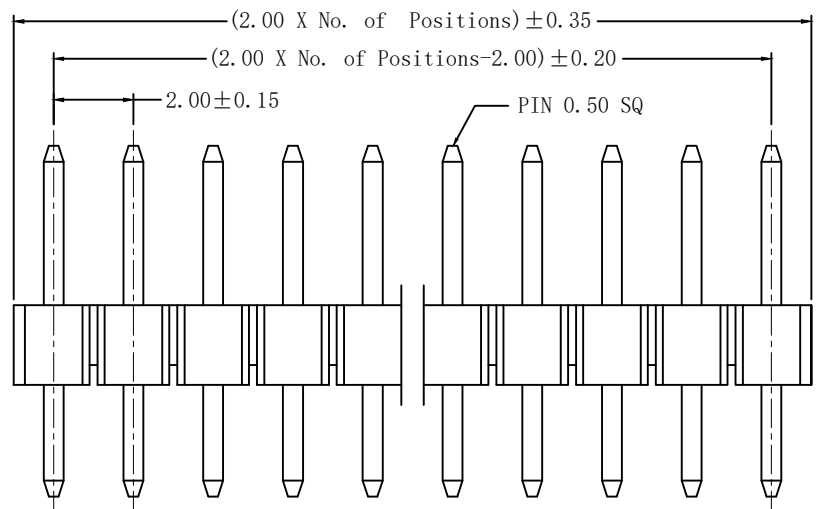

EC2.0D-2S-2*xxP G-A/ B

单排芯数
01~40P

电镀
G: 镀金Gold Flash
1G: 镀金1u"
3G: 镀金3u"
(镀金可订制)

针长
(可订制)

针长
(可订制)

弯曲度: 2*02P ~ 2*20P 0.30 MAX.
2*21P ~ 2*30P 0.40 MAX.
2*31P ~ 2*40P 0.50 MAX.

技术参数: SPECIFICATIONS

额定电流 (Current Rating): 2A
 绝缘电阻 (Insulation Resistance): 1000MΩ Min.
 额定电压 (Dielectric Withstanding Voltage): AC 500V
 工作温度 (Operating Temperature): -40°C ~ +105°C
 最大加工温度 (Max Processing Temp): (230°C for 30~60 seconds)
 (260°C for 10 seconds)

接触材料 (Contact Material): 黄铜 (Brass)
 塑胶材料 (Insulator Material): 尼龙 (Nylon)-9T, UL 94V-0; 颜色: 黑色
 接触电镀 (Contact Plating): 镀金 (Gold plated)
 (电镀规格可根据客户要求来定制)
 Opitonal planting on request.

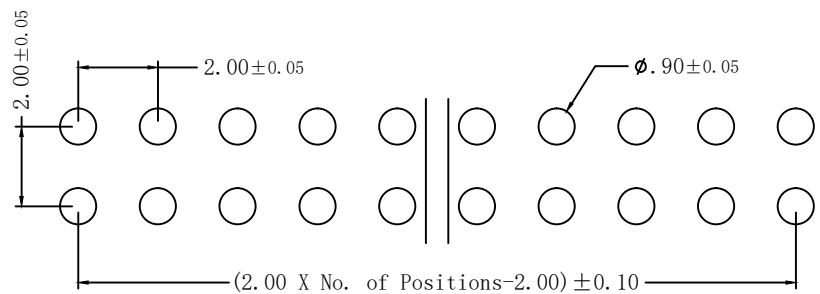

Recommended PCB Layout

公差:	版次:	A	易芯精密科技(浙江)有限公司 Easychips Precision Technology (Zhejiang) Co., Ltd.	型号: EC2-2S-2*xxPG-A/B 描述: 2.0双排直脚排针	签名	日期
. X ±0.35	比例:				绘图:	
. XX ±0.25	单位:	mm	确认:			
. XXX ±2°	页码:	1/1	审核:			
LNLGB	图号:					