

版次	变更内容	审核	日期

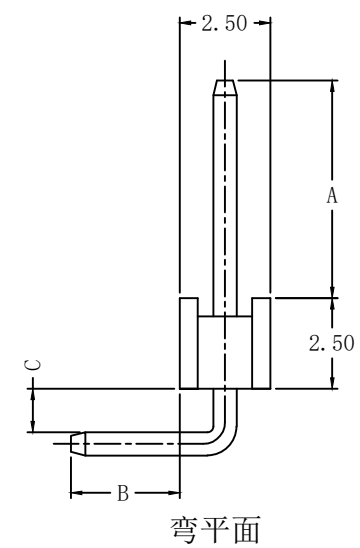
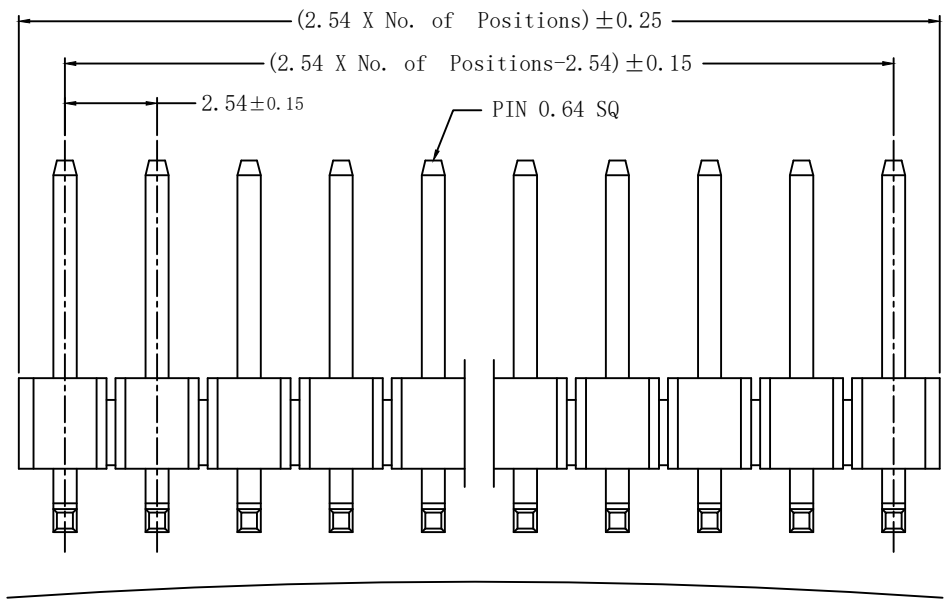

EC254-1\*xxP G-A/ B/ C

芯数 01~40P  
 电镀 G: 镀金Gold Flash  
 1G: 镀金1u"  
 3G: 镀金3u"  
 (镀金可订制)

内距 (可订制)  
 针长 (可订制)  
 针长 (可订制)

弯曲度: 1\*02P ~ 1\*20P 0.30 MAX.  
 1\*21P ~ 1\*30P 0.40 MAX.  
 1\*31P ~ 1\*40P 0.50 MAX.

技术参数: SPECIFICATIONS

额定电流 (Current Rating): 3A  
 绝缘电阻 (Insulation Resistance): 1000MΩ Min.  
 额定电压 (Dielectric Withstanding Voltage): AC 500V  
 工作温度 (Operating Temperature): -40°C ~ +105°C  
 最大加工温度 (Max Processing Temp): (230°C for 30~60 seconds)  
 (260°C for 10 seconds)

接触材料 (Contact Material): 黄铜 (Brass)  
 塑胶材料 (Insulator Material): 尼龙 (Nylon)-9T, UL 94V-0; 颜色: 黑色  
 接触电镀 (Contact Plating): 镀金 (Gold plated)  
 (电镀规格可根据客户要求来定制)  
 (Optional plating on request.)



Recommended PCB Layout

公差:	版次:	A	 <b>易芯精密科技(浙江)有限公司</b> Easychips Precision Technology (Zhejiang) Co., Ltd.			
. X ±0.35	比例:					
. XX ±0.25	单位:	mm	型号:	EC254-1*xxPG-A/B/C	签名	日期
. XXX ±2°	页码:	1/1	描述:	2.54单排弯脚排针	绘图:	
LNLB	图号:				确认:	
					审核:	