

1 2 3 4 5 6 7 8 9 10

A  
B  
C  
D  
E  
F  
G

|                   |                             |                   |
|-------------------|-----------------------------|-------------------|
| 目錄<br><b>MAPX</b> | 設變內容<br><b>MODIFICATION</b> | 日期<br><b>DATE</b> |
|                   |                             |                   |

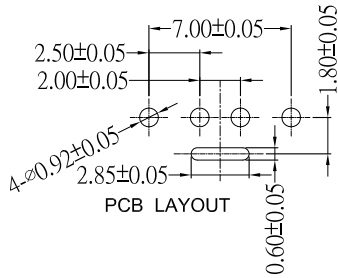
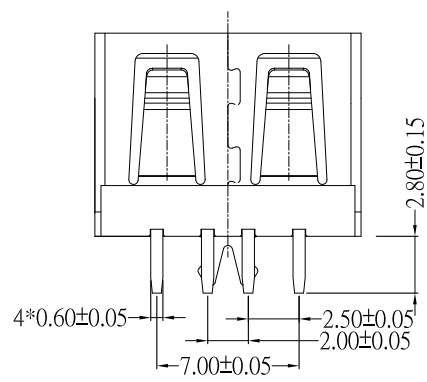
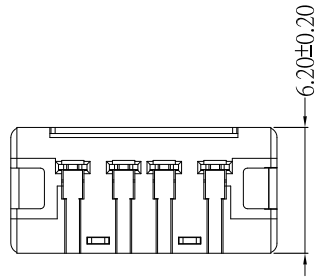
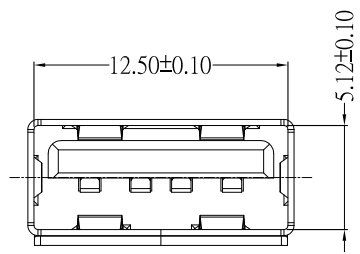
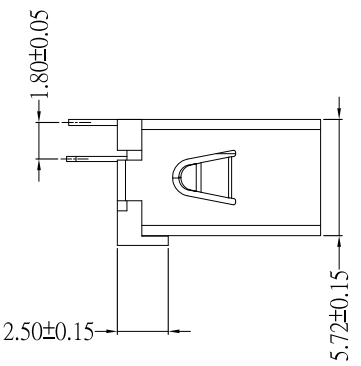
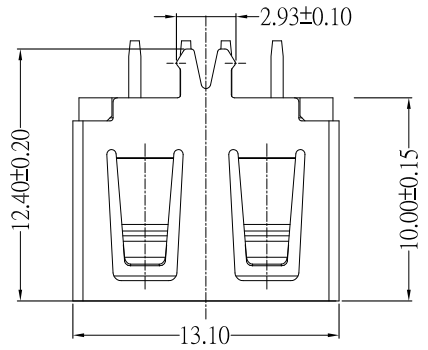

NOTES:

- 1. HOUSING: SEE NOTES,
- TERMINAL: SEE NOTES.
- SHELL: SEE NOTES.

SPECIFICATION:

- 1. ELECTRICAL CHARACTERISTIC:
  - CONTACT RESISTANCE: 30MΩ MAX
  - DIELECTRIC WITHSTANDING VOLTAGE: 500V AC FOR 1MIN
  - INSULATION RESISTANCE: 1000MΩ MIN
- 2. MECHANICAL CHARACTERISTIC:
  - INSERTION FORCE: 35N(3.57KGF) MAX
  - EXTRACTION FORCE: 10~35N(1.02~3.57KGF)MIN
  - DURABILITY: 1500 CYCLES EXTRACTION FORCE:10~35N
- 3. ENVIRONMENTAL:
  - OPERATING TEMPERATURE: -55℃+85℃
- 4. Contact finish:
  - 01:Selective Gold Flash
  - 02:Selective Gold 3U"
  - 03:Selective Gold 5U"
  - 04:Selective Gold 15U"
  - 05:Selective Gold 30U"

|                                     |       |   |            |               |                          |
|-------------------------------------|-------|---|------------|---------------|--------------------------|
| 产品图<br>PRODUCT CHART DWG            |       | 易芯精密科技(浙江)有限公司<br>Easychips Precision Technology (Zhejiang) Co., Ltd. |            |               |                          |
| 公差一览表<br>TOLERANCE UNLESS OTHERWISE |       | 单位<br>UNITS   | MM         | 制图<br>DRAWING | 产品料号<br>PRODUCT PART NO. |
| X.                                  | ±0.25 | X'.   | ±5'        | 比例<br>SCALE   | 产品名称<br>PRODUCT NO.      |
| .X                                  | ±0.20 | .X'   | ±2'        |               |                          |
| .XX                                 | ±0.15 | .XX'  | ±1'        | 日期<br>DATE    | 角法<br>VIEW               |
| .XXX                                | ±0.10 | .XXX'   | ±0.5'      |               |                          |
|                                     |       | 2013. 05. 10  | 核准<br>APPD | 版本<br>VER     | A0                       |

1 2 3 4 5 6 7 8 9 10