

MAPX	MODIFICATION	DATE

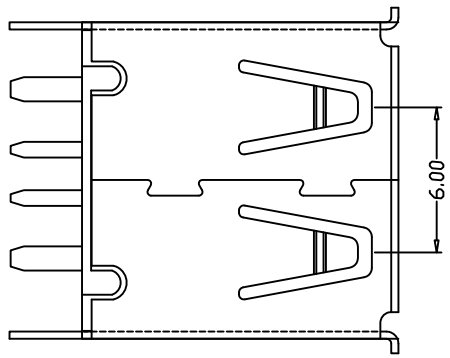
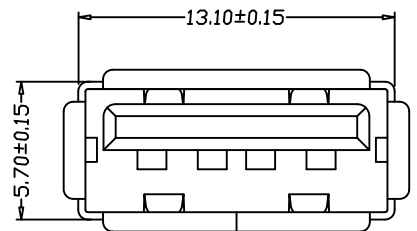
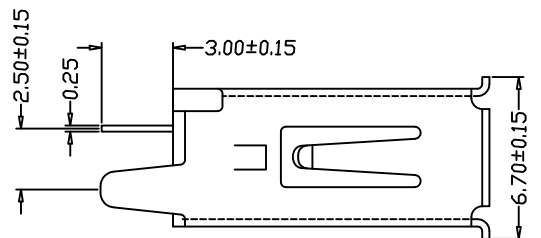
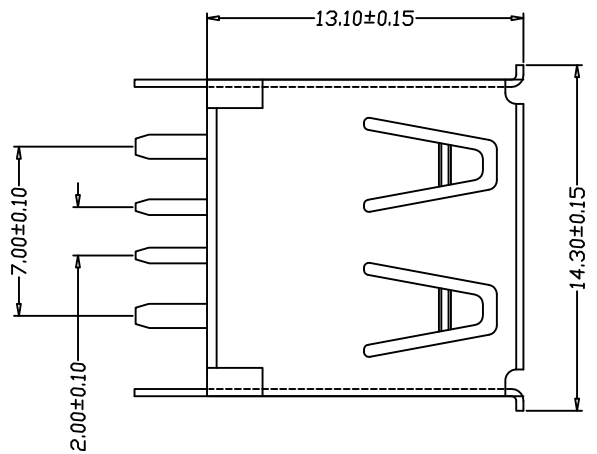

NOTES:

- 1. HOUSING: SEE NOTES, UL94V-0 .
- TERMINAL: SEE NOTES.
- SHELL: SEE NOTES.

SPECIFICATION:

- 1. ELECTRICAL CHARACTERISTIC:
 - Current rating:5.0A Max
 - CONTACT RESISTANCE: 30MΩ MAX
 - DIELECTRIC WITHSTANDING VOLTAGE: 500V AC FOR 1MIN
 - INSULATION RESISTANCE: 1000MΩ MIN
- 2. MECHANICAL CHARACTERISTIC:
 - INSERTION FORCE: 35N(3.57KGF) MAX
 - EXTRACTION FORCE: 10~35N(1.02~3.57KGF)MIN
 - DURABILITY: 1500 CYCLES EXTRACTION FORCE:10~35N
5000 CYCLES MIN
5000 CYCLES EXTRACTION FORCE:3~35N

3. ENVIRONMENTAL:

OPERATING TEMPERATURE: -55°C+85°C

4. Contact finish:

- 01:Selective Gold Flash
- 02:Selective Gold 3U"
- 03:Selective Gold 5U"
- 04:Selective Gold 15U"
- 05:Selective Gold 30U"

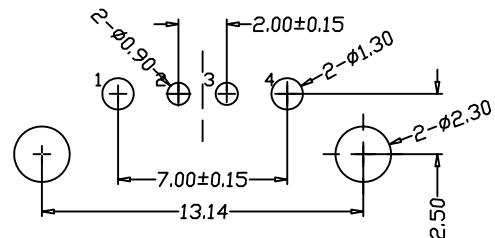

PCB LAYOUT

产品图 PRODUCT CHART DWG									
公差一览表 TOLERANCE UNLESS OTHERWISE				易芯精密科技(浙江)有限公司 Easychips Precision Technology (Zhejiang) Co., Ltd.					
X.	±0.25	X.	±5.°	单位	MM	制图	Z-Y-B	制图料号	A916-EC252A1112Y10210
.X	±0.20	.X	±2.°	比例	1:1	审核		产品名称	AF大电流13.1直脚180度有边铜壳PBT橙色/5A
.XX	±0.15	.XX	±1.°	日期	2014.07.24	核准		角法	
.XXX	±0.10	.XXX	±0.5°	DATE		APPD		VIEW	版本 VER AD