

REV.	ECN NO	LOCATIONS	DESCRIPTION	DATE

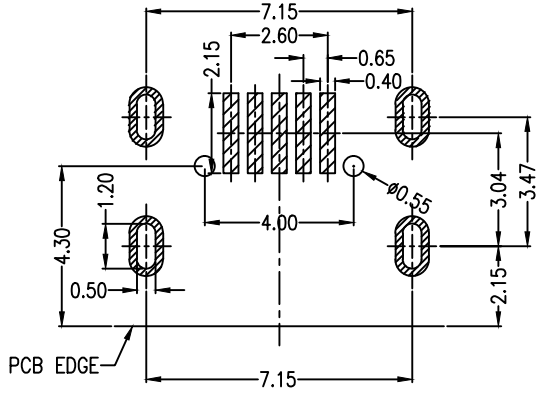
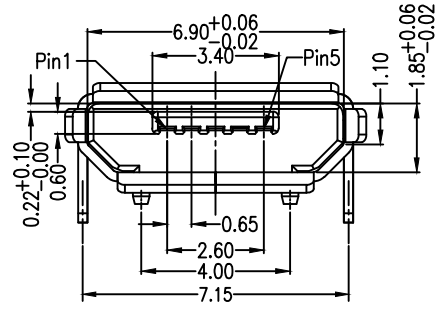
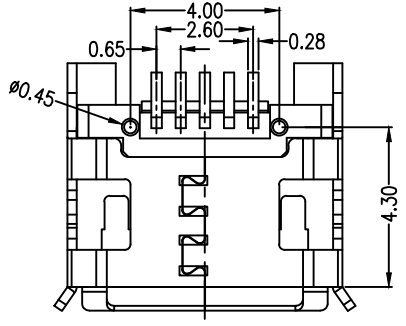
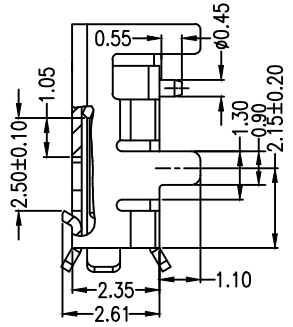
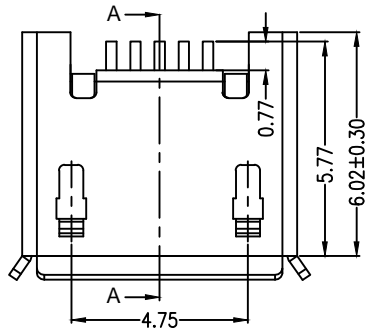
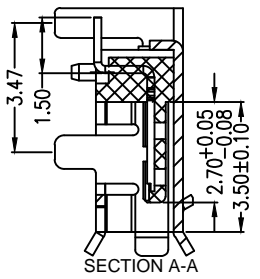
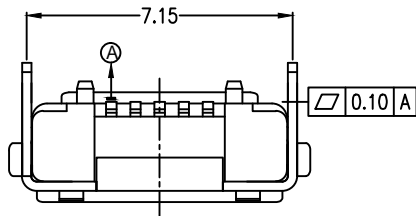

RECOMMENDED PCB LAYOUT
PCB图仅供参考

- Note:
- Material:
 - Housing: High temperature thermoplastic with g.f,UL94v-0
 - Contact: copper alloy,t=0.20mm
 - Shell: copper alloy or SUS,t=0.25mm
 - Specification:
 - Current rating:1,5PIN 1.8A Max/2,3,4PIN 1A Max
 - Dielectric withstanding voltage: 100 V(ac) for 1 min.
 - Contact resistance: 30 mΩ Max.
 - Insulation resistance: 100 MΩ Min.
 - Total mating force: 3.57 Kgf Max.
 - Total unmating force: 1.0 Kgf Min.
 - Temperature range: -30°C~80°C

PART NO: 920-A52A2021S10108		MATERIAL: SEE NOTE		易芯精密科技(浙江)有限公司 Easychips Precision Technology (Zhejiang) Co., Ltd.	
MODEL NO: XX		FINISH: SEE NOTE			
UNIT: MM	SIZE: A4	COLOR: SEE NOTE		TITLE: MICRO/5P-F B型四脚插板有边7.2脚长1.1有柱端子 加长0.75SMT	
TOLERANCE UNSPECIFIED		DR: xiayouhong		DWG NO: B920-ECA52A2021S10108	
.x	±0.15	CHK:		REV: A	
.xx	±0.10	APP:		SCALE: 5:1	
.xxx	±0.05			DATE: 2012.05.21	
Ang	±1°				