

MAPX	MODIFICATION	DATE

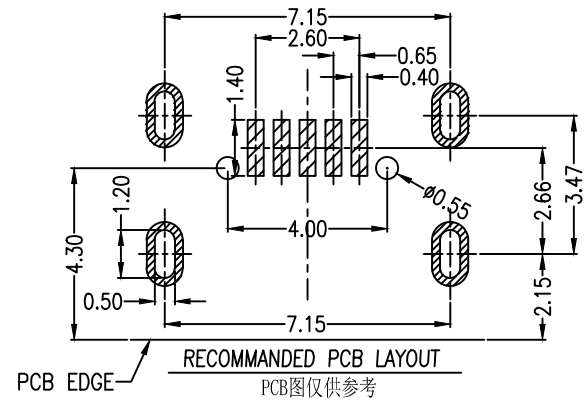
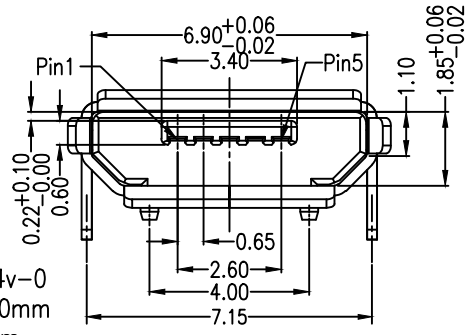
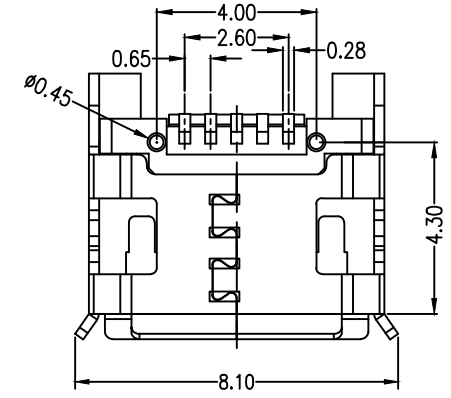
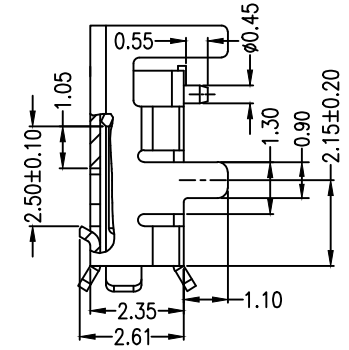
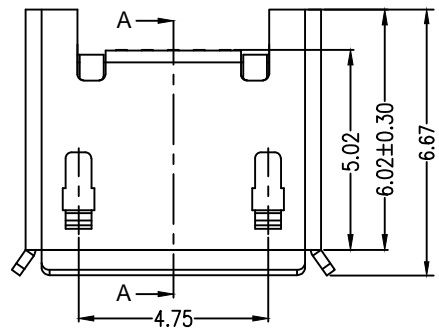
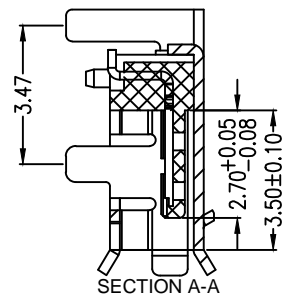
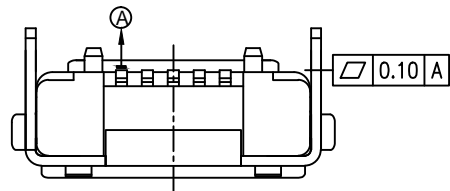

Note:  
1. Material:

- 1.1 Housing: High temperature thermoplastic with g.f,UL94v-0
- 1.2 Contact: copper alloy,t=0.20mm
- 1.3 Shell: copper alloy,t=0.25mm

2. Specification:

- 2.1 Current rating:1,5PIN 1.8A Max/2,3,4PIN 1A Max.
- 2.2 Dielectric withstanding voltage: 100 V(ac) for 1 min.
- 2.3 Contact resistance: 30 mΩ Max.
- 2.4 Insulation resistance: 100 MΩ Min.
- 2.5 Total mating force: 3.57 Kg Max.
- 2.6 Total unmating force: 1.0 Kg Min.
- 2.7 Temperature range: -30°C~80°C

<p>产品图 PRODUCT CHART DWG</p>		<p>易芯精密科技(浙江)有限公司 Easychips Precision Technology (Zhejiang) Co., Ltd.</p>			
<p>公差一览表 TOLERANCE UNLESS OTHERWISE</p>		单位 UNITS	MM	制图 DRAWING	制图料号 PRODUCT PART NO.
X.	±0.35	X.	±5.°	审核 CHKD	B920-ECA52A2021S10109
.X	±0.30	.X	±2.°	日期 DATE	产品名称 PRODUCT NAME
.XX	±0.20	.XX	±1.°	核准 APPD	MICRO/5S-B 四脚DIP7.2有边脚长1.1有柱短端SMT
.XXX	±0.10	.XXX	±0.5°	角法 VIEW	版本 VER
					A0