

MAPX	MODIFICATION	DATE

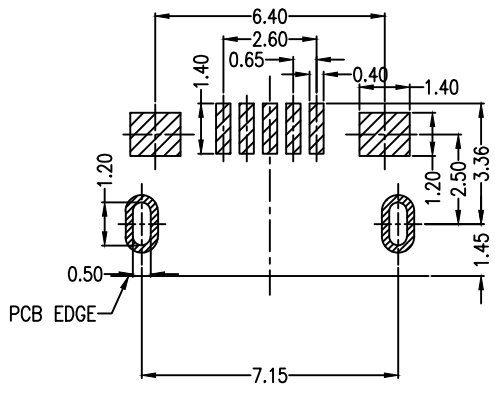
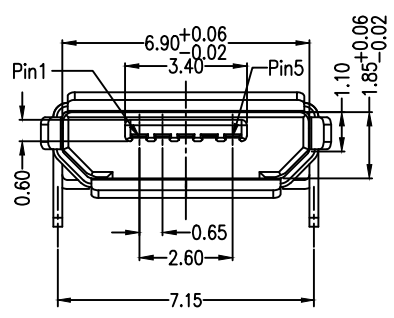
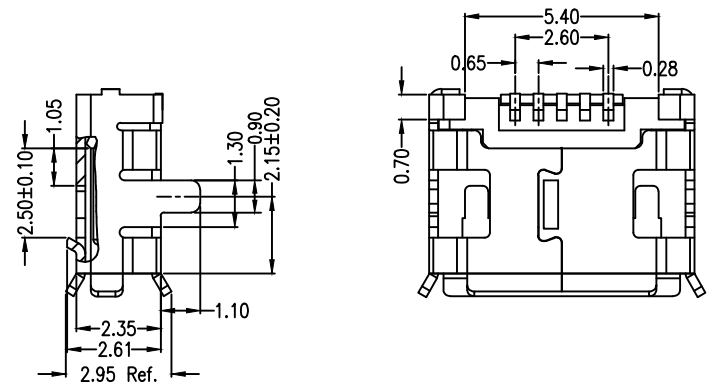
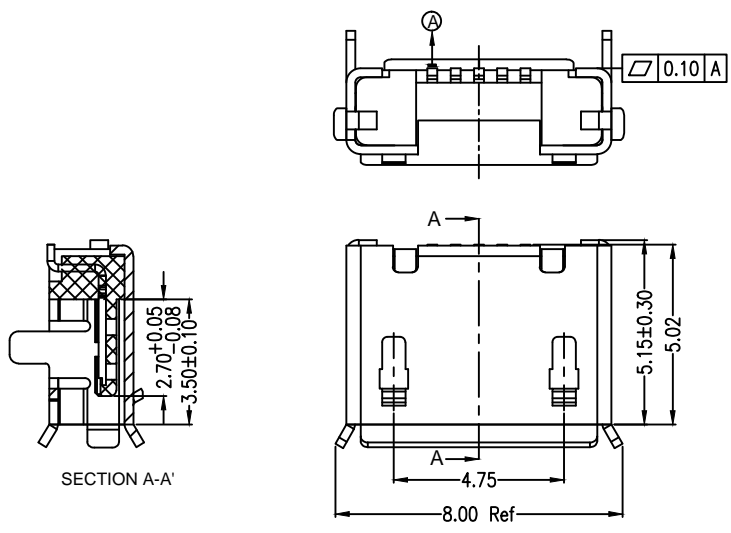

RECOMMENDED PCB LAYOUT
PCB图仅供参考

- Note:
- Material:
 - Housing: High temperature thermoplastic with g.f,UL94v-0
 - Contact: copper alloy,t=0.20mm
 - Shell: copper or sus304,t=0.25mm
 - Specification:
 - Current rating:1.5PIN 1.8A Max/2,3,4PIN 1A Max.
 - Dielectric withstanding voltage: 100 V(ac) for 1 min.
 - Contact resistance: 30 mΩ Max.
 - Insulation resistance: 100 MΩ Min.
 - Total mating force: 3.57 Kgf Max.
 - Total unmating force: 1.0 Kgf Min.
 - Temperature range: -30°C~80°C

产品图 PRODUCT CHART DWG		易芯精密科技(浙江)有限公司 Easychips Precision Technology (Zhejiang) Co.,Ltd.			
公差一览表 TOLERANCE UNLESS OTHERWISE		单位 UNITS	MM	制图 DRAWING	制料料号 PRODUCT PART NO.
X.	±0.30	X.	±5.°	审核 CHKD	B920-ECA54A2021S10100
.X	±0.25	.X	±2.°		产品名称 PRODUCT NO.
.XX	±0.20	.XX	±1.°		MICRO/5P-F 两脚DIP7.2有边脚长 1.1不锈钢无柱加焊脚短端子SMT
.XXX	±0.10	.XXX	±0.5°		角法 VIEW
日期 DATE	2019.11.23	核准 APPD		版本 VER	A0