

MAPX	MODIFICATION	DATE

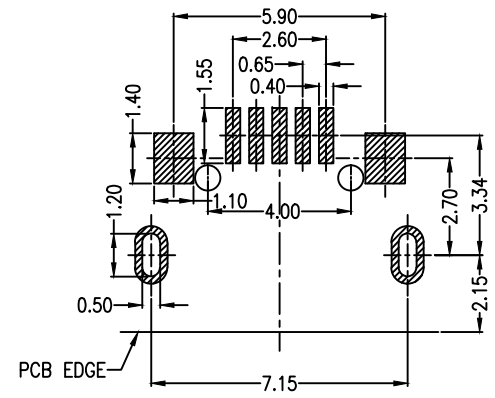
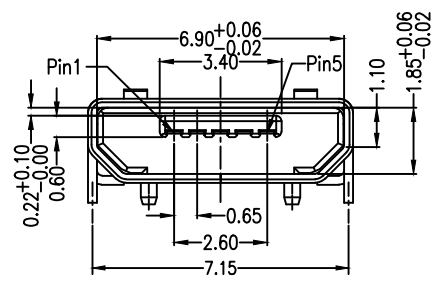
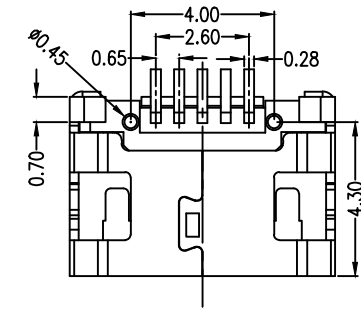
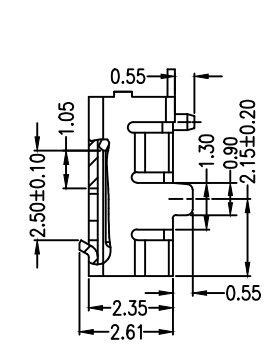
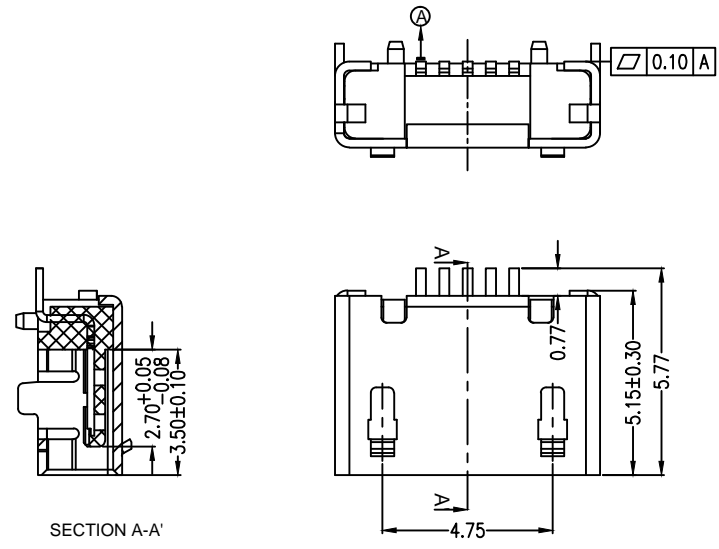

- Note:
- Material:
 - Housing: High temperature thermoplastic with g.f,UL94v-0
 - Contact: copper alloy,t=0.20mm
 - Shell: copper alloy,t=0.25mm
 - Specification:
 - Current rating:1.5PIN 1.8A Max/2,3,4PIN 1A Max.
 - Dielectric withstanding voltage: 100 V(ac) for 1 min.
 - Contact resistance: 30 mΩ Max.
 - Insulation resistance: 100 MΩ Min.
 - Total mating force: 3.57 Kgf Max.
 - Total unmating force: 1.0 Kgf Min.
 - Temperature range: -30°C~80°C

RECOMMENDED PCB LAYOUT
PCB图仅供参考

产品图 PRODUCT CHART DWG		易芯精密科技(浙江)有限公司 Easychips Precision Technology (Zhejiang) Co., Ltd.			
公差一览表 TOLERANCE UNLESS OTHERWISE		单位 UNITS	MM	制图 DRAWING	制图料号 PRODUCT PART NO.
.X	±0.30	X.	±5.°	审核 CHKD	产品名称 PRODUCT NO.
.X	±0.25	.X	±2.°		
.XX	±0.20	.XX	±1.°	核准 APPD	角法 VIEW
.XXX	±0.10	.XXX	±0.5°		
		日期 DATE	2019.11.23	角法 VIEW	版本 VER
					A0

A
B
C
D
E
F
G

A
B
C
D
E
F
G

1 2 3 4 5 6 7 8 9 10

1 2 3 4 5 6 7 8 9 10