

MAPX	MODIFICATION	DATE

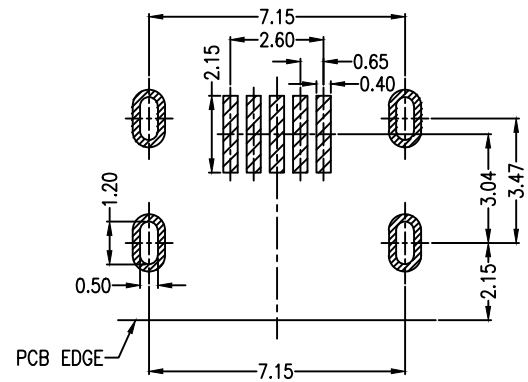
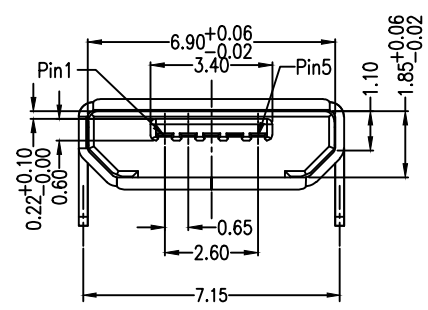
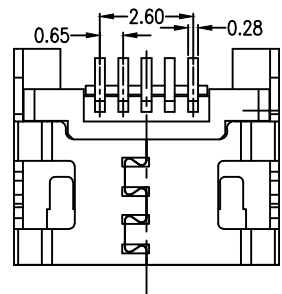
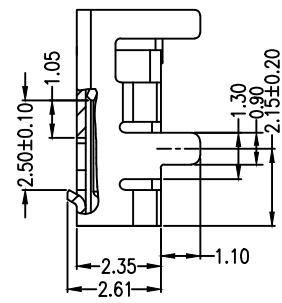
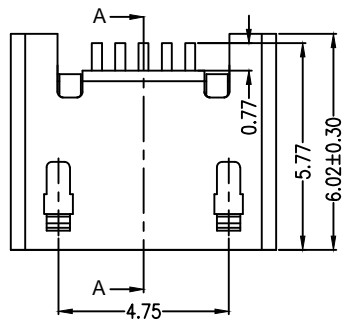
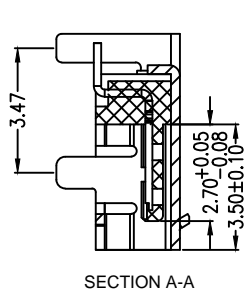
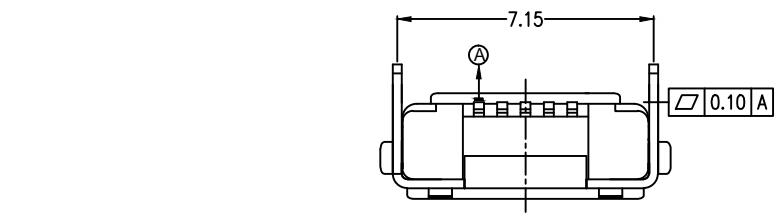

RECOMMENDED PCB LAYOUT
PCB图仅供参考

- Note:
- Material:
 - Housing: High temperature thermoplastic with g.f,UL94v-0
 - Contact: copper alloy,t=0.20mm
 - Shell: copper alloy or SUS,t=0.25mm
 - Specification:
 - Current rating:1.5PIN 1.8A Max/2,3,4PIN 1A Max.
 - Dielectric withstanding voltage: 100 V(ac) for 1 min.
 - Contact resistance: 30 mΩ Max.
 - Insulation resistance: 100 MΩ Min.
 - Total mating force: 3.57 Kgf Max.
 - Total unmating force: 1.0 Kgf Min.
 - Temperature range: -30°C~80°C

???				易芯精密科技(浙江)有限公司		Easychips Precision Technology (Zhejiang) Co., Ltd.	
PRODUCT CHART DWG				???	???	???	???
TOLERANCE UNLESS OTHERWISE		?? UNITS	MM	?? DRAWING	YANG	???	PRODUCT PART NO. B920-ECA62A2021S10106
X.	±0.30	X.	±5.°	?? SCALE	1:1	?? CHKD	???
.X	±0.25	.X	±2.°	?? DATE	2019.11.23	?? APPD	???
.XX	±0.20	.XX	±1.°	?? VIEW	??	??	??
.XXX	±0.10	.XXX	±0.5°	??	??	??	??

MICRO 5P-F B型四脚插板7.2无卷边无柱端子加长0.75

VIEW	VER	AD
------	-----	----