

MAPX	MODIFICATION	DATE

- Note:
- Material:
    - Housing: High temperature thermoplastic with g.f,UL94v-0
    - Contact: copper alloy,t=0.20mm
    - Shell: copper alloy,t=0.25mm
  - Specification:
    - Current rating:1.5PIN 1.8A Max/2,3,4PIN 1A Max.
    - Dielectric withstanding voltage: 100 V(ac) for 1 min.
    - Contact resistance: 30 mΩ Max.
    - Insulation resistance: 100 MΩ Min.
    - Total mating force: 3.57 Kgf Max.
    - Total unmating force: 1.0 Kgf Min.
    - Temperature range: -30°C~80°C

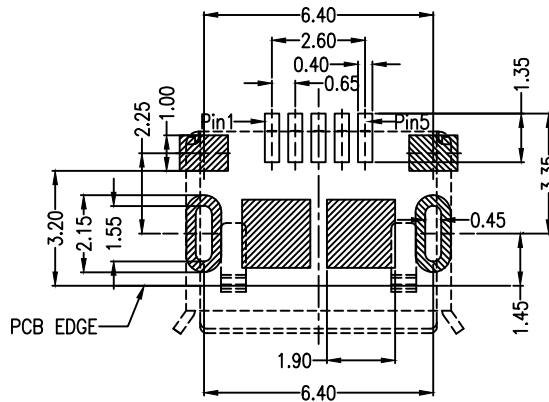

<b>产品图</b> PRODUCT CHART DWG		<b>易芯精密科技(浙江)有限公司</b> Easychips Precision Technology (Zhejiang) Co., Ltd.			
<b>公差一览表</b> TOLERANCE UNLESS OTHERWISE		单位 UNITS	MM	制图 DRAWING	制料号 PRODUCT PART NO.
X.	±0.30	X.	±5.°		B920-ECB52A2021S10101
.X	±0.25	.X	±2.°	比例 SCALE	产品名称 PRODUCT NO.
.XX	±0.20	.XX	±1.°	1:1	MICRO 5S B型6.4有边无柱有后盖两脚长1.0加焊脚短端SMT
.XXX	±0.10	.XXX	±0.5°	日期 DATE	角法 VIEW
				2019.11.23	核准 APPD
					版本 VER
					A0