

RoHS

MAPX

MODIFICATION

DRW

DATE

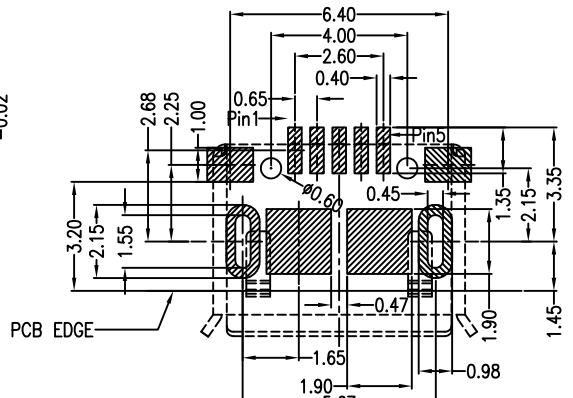
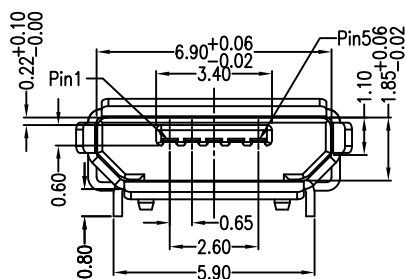
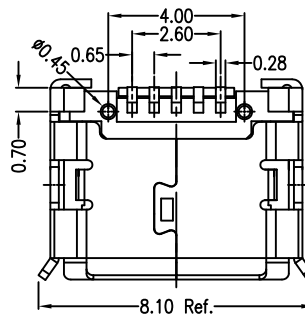
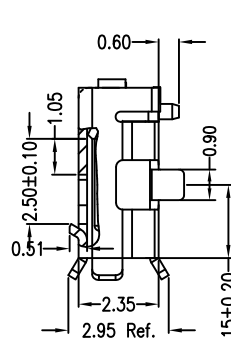
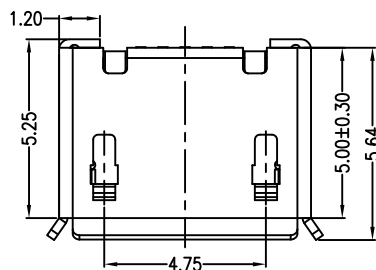
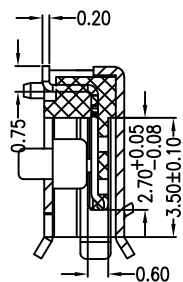
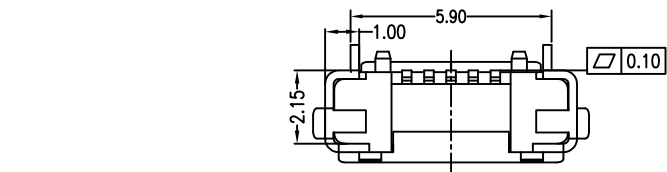

RECOMMENDED PCB LAYOUT PCB图仅供参考

Note:

1.Material:

- 1.1 Housing: High temperature thermoplastic with g.f,UL94v-0
- 1.2 Contact: copper alloy,t=0.20mm contact area Au flash plating;
- 1.3 Shell:copper or SUS304,t=0.25mm Sn plating 60U" min.

2.Specification:

- 2.1 Current rating:1,5PIN 1.8A Max/2,3,4PIN 1A Max.
- 2.2 Dielectric withstanding voltage: 100 V(ac) for 1 min.
- 2.3 Contact resistance: 30 mΩ Max.
- 2.4 Insulation resistance: 100 MΩ Min.
- 2.5 Total mating force: 3.57 Kgf Max.
- 2.6 Total unmating force: 1.0 Kgf Min.
- 2.7 Temperature range: -30°C~80°C
- 2.8 Solderability: 90% area min;

产品图

PRODUCT CHART DWG

公差一览表

TOLERANCE UNLESS OTHERWISE

X.	±0.35	X.	±5°
.X	±0.20	.X	±2°
.XX	±0.15	.XX	±1°
.XXX	±0.05	.XXX	±0.5°



易芯精密科技(浙江)有限公司
Easychips Precision Technology (Zhejiang) Co., Ltd.

单位 UNITS	MM	制图 DRAWING	制图料号 PRODUCT PART NO.	B920-ECC52A2021S10100
比例 SCALE	1:1	审核 CHKD	产品名称 PRODUCT NO.	MICRO SS B型两脚插板5.9有边有柱有后盖加焊脚端SMT
日期 DATE	2016-09-09	核准 APPD	角法 VIEW	版本 VER
				A0