

目錄
MAPX

設變內容
MODIFICATION

日期
DATE

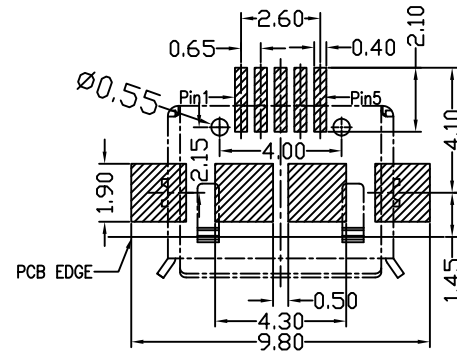
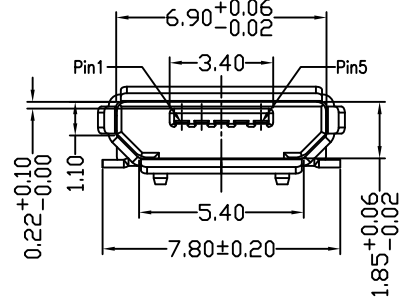
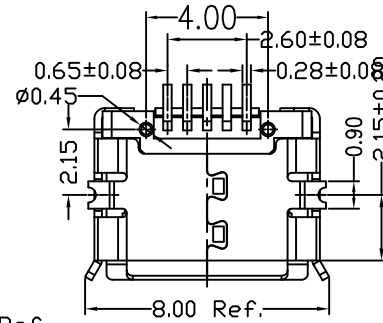
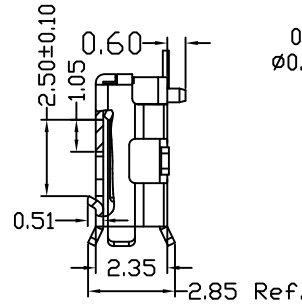
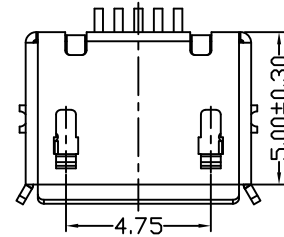
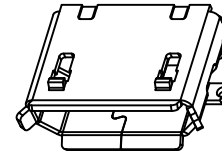
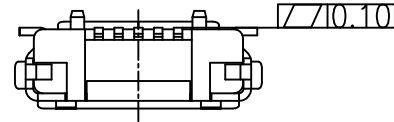
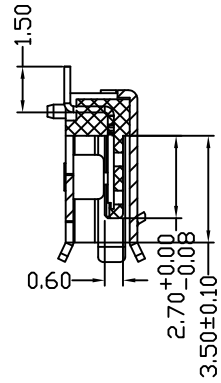

RECOMMENDED PCB LAYOUT
PCB图仅供参考

Note:

1.Material:

- 1.1 Housing: High temperature thermoplastic with g.f,UL94v-0
- 1.2 Contact: copper alloy,t=0.20mm
- 1.3 Shell: copper alloy,t=0.25mm

2.Specification:

- 2.1 Current rating:1,5PIN 1.8A Max/2,3,4PIN 1A Max.
- 2.2 Dielectric withstanding voltage: 100 V(ac) for 1 min.
- 2.3 Contact resistance: 30 mΩ Max.
- 2.4 Insulation resistance: 100 MΩ Min.
- 2.5 Total mating force: 3.57 Kgf Max.
- 2.6 Total unmating force: 1.0 Kgf Min
- 2.7 Temperature range: -30~80

产品图
PRODUCT CHART DWG



易芯精密科技(浙江)有限公司
Easychips Precision Technology (Zhejiang) Co., Ltd.

公差一览表 TOLERANCE UNLESS OTHERWISE				单位 UNITS	MM	制图 DRAWING	产品料号 PRODUCT PART NO.	B920-EC52A2021S10104				
X.	±0.30	X'.	±5°	比例 SCALE	1:1	审核 CHKD	产品名称 PRODUCT NO.	MICRO 5S B型两脚贴板有边有柱SMT端子 加长0.75				
.XX	±0.15	.XX'	±1°				日期 DATE	2021-04-15	核准 APPD	角法 VIEW	版本 VER	A0
.XXX	±0.10	.XXX'	±0.5°									