

MAPX	MODIFICATION	DATE

A  
B  
C  
D  
E  
F  
G

A  
B  
C  
D  
E  
F  
G

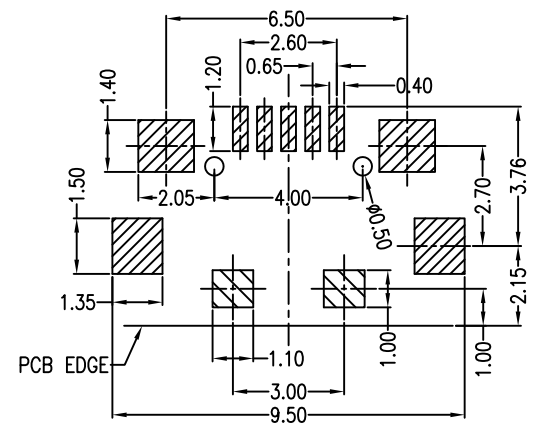
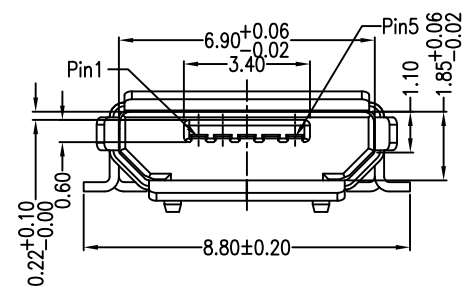
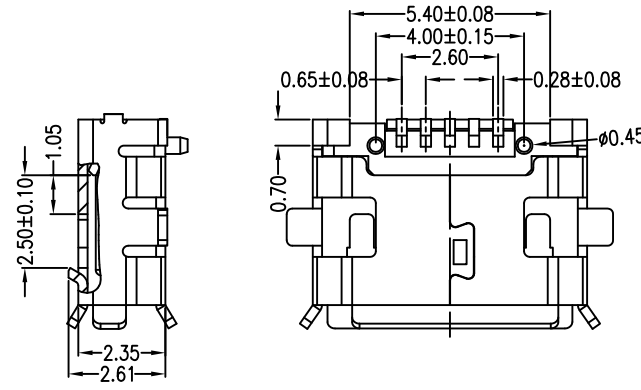
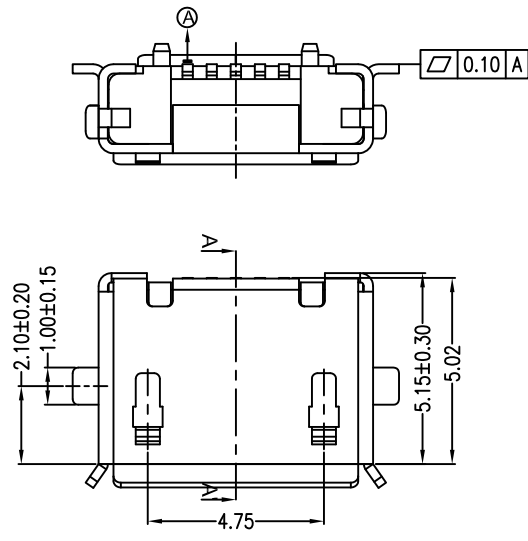
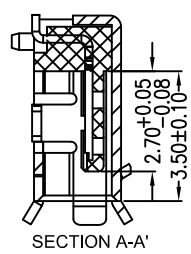

- Note:
- Material:
    - Housing: High temperature thermoplastic with g.f,UL94v-0
    - Contact: copper alloy,t=0.20mm
    - Shell: copper alloy,t=0.25mm
  - Specification:
    - Current rating:1,5PIN 1.8A Max/2,3,4PIN 1A Max
    - Dielectric withstanding voltage: 100 V(ac) for 1 min.
    - Contact resistance: 30 mΩ Max.
    - Insulation resistance: 100 MΩ Min.
    - Total mating force: 3.57 Kgf Max.
    - Total unmating force: 1.0 Kgf Min
    - Temperature range: -30°C~80°C

RECOMMENDED PCB LAYOUT PCB图仅供参考

产品图 PRODUCT CHART DWG		易芯精密科技(浙江)有限公司 Easychips Precision Technology (Zhejiang) Co.,Ltd.			
公差一览表 TOLERANCE UNLESS OTHERWISE		单位	制图	制图料号	B920-ECD52A2021S10109
X.	±0.30	MM	DRAWING	PRODUCT PART NO.	
.X	±0.25	比例	审核	产品名称	MICRO 5S B型四脚全贴有边有柱外焊脚 长8.7LCP黑胶短端
.XX	±0.15	SCALE	CHKD	PRODUCT NO.	
.XXX	±0.10	日期	核准	角法	版本 VER
		DATE	APPD	VIEW	

1 2 3 4 5 6 7 8 9 10