

| | | |
|------|--------------|------|
| MAPX | MODIFICATION | DATE |
|------|--------------|------|

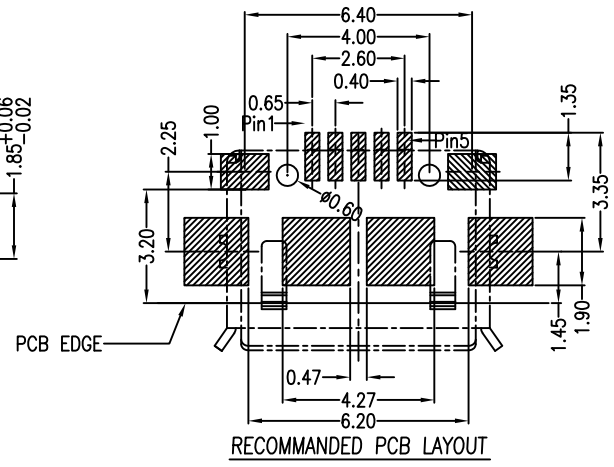
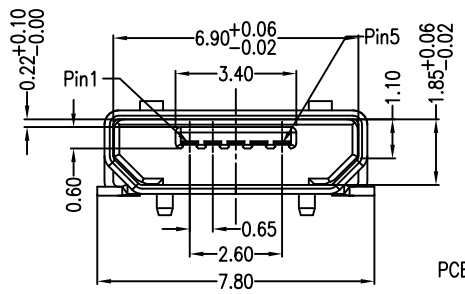
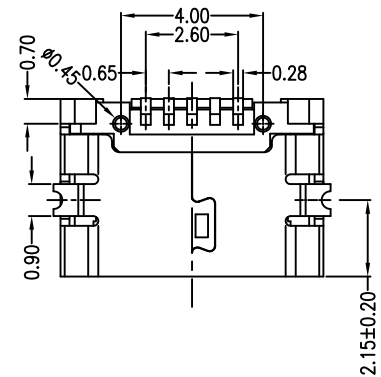
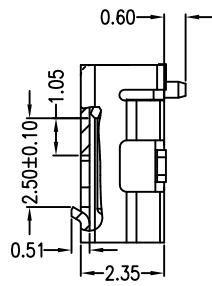
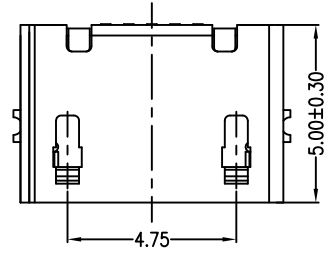
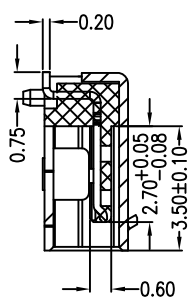
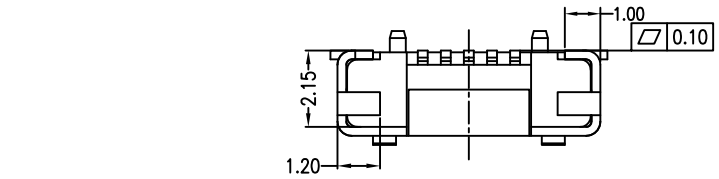

- Note:
- Material:
 - Housing: High temperature thermoplastic with g.f,UL94v-0
 - Contact: copper alloy,t=0.20mm
 - Shell: copper or sus304,t=0.25mm
 - Specification:
 - Current rating:1.5PIN 1.8A Max/2,3,4PIN 1A Max.
 - Dielectric withstanding voltage: 100 V(ac) for 1 min.
 - Contact resistance: 30 mΩ Max.
 - Insulation resistance: 100 MΩ Min.
 - Total mating force: 3.57 Kgf Max.
 - Total unmating force: 1.0 Kgf Min
 - Temperature range: -30°C~80°C

产品图

PRODUCT CHART DWG

| 公差一览表 TOLERANCE UNLESS OTHERWISE | | | |
|-------------------------------------|-------|------|-------|
| X. | ±0.25 | X. | ±5° |
| .X | ±0.20 | .X | ±2° |
| .XX | ±0.15 | .XX | ±1° |
| .XXX | ±0.10 | .XXX | ±0.5° |



易芯精密科技(浙江)有限公司
Easychips Precision Technology (Zhejiang) Co., Ltd.

| | | | | |
|-------------|------------|---------------|-------------------------|---------------------------------|
| 单位 UNITS | MM | 制图 DRAWING | 制图料号 PRODUCT PART NO | B920-ECD62A2021S10100 |
| 比例 SCALE | 1:1 | 审核 CHKD | 产品名称 PRODUCT NO | MICRO 5S B型两脚贴板无边 有柱加焊脚短端SMT |
| 日期 DATE | 2012.06.10 | 核准 APPD | 角法 VIEW | 版本 VER |



版本
VER

AD