

MAPX	MODIFICATION	DATE

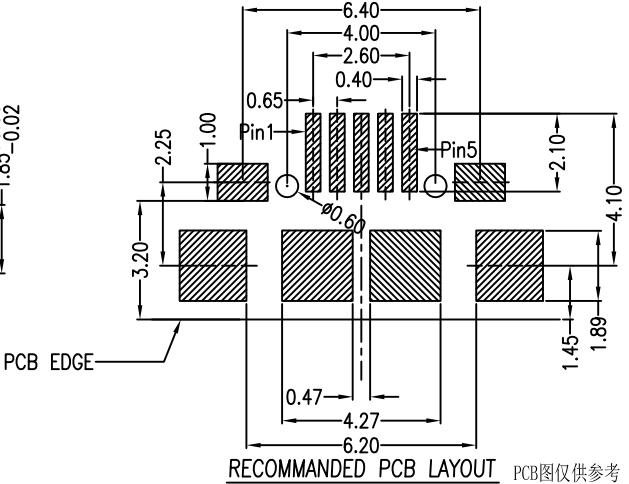
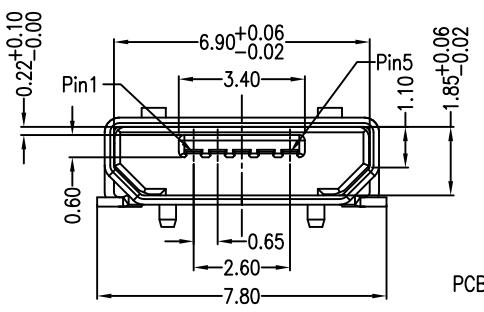
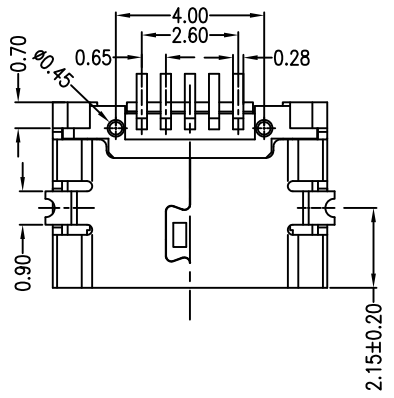
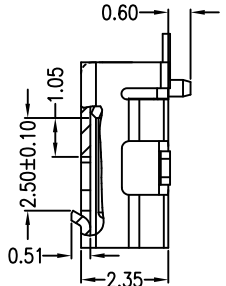
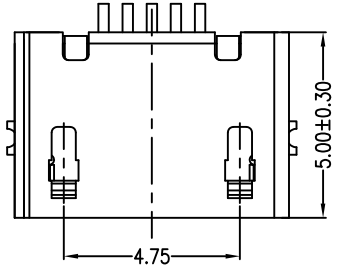
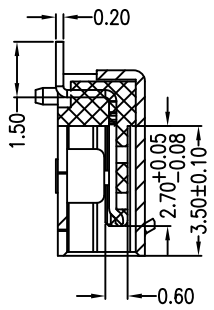
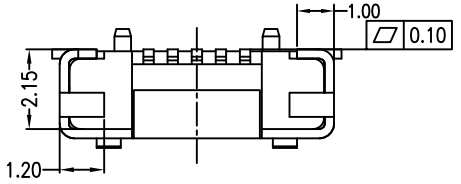

- Note:
- Material:
 - Housing: High temperature thermoplastic with g.f,UL94v-0
 - Contact: copper alloy,t=0.20mm
 - Shell: copper or sus304,t=0.25mm
 - Specification:
 - Current rating:1,5PIN 1.8A Max/2,3,4PIN 1A Max.
 - Dielectric withstanding voltage: 100 V(ac) for 1 min.
 - Contact resistance: 30 mΩ Max.
 - Insulation resistance: 100 MΩ Min.
 - Total mating force: 3.57 Kgf Max.
 - Total unmating force: 1.0 Kgf Min
 - Temperature range: -30°C~80°C

产品图 PRODUCT CHART DWG							
公差一览表 TOLERANCE UNLESS OTHERWISE				单位	制图	制图料号	B920-ECD62A2021S10102
X.	±0.30	X.	±5.°	UNITS	MM	DRAWING	PRODUCT PART NO.
.X	±0.25	.X	±2.°	比例	1:1	审核	产品名称
.XX	±0.15	.XX	±1.°	SCALE		CHKD	MICRO 5S B型两脚贴板无边有柱加焊脚
.XXX	±0.10	.XXX	±0.5°	日期	2021-04-16	核准	端子加长0.75
				DATE		APPD	角法
							VIEW
							版本
							VER
							AO