

MAPX	MODIFICATION	DATE

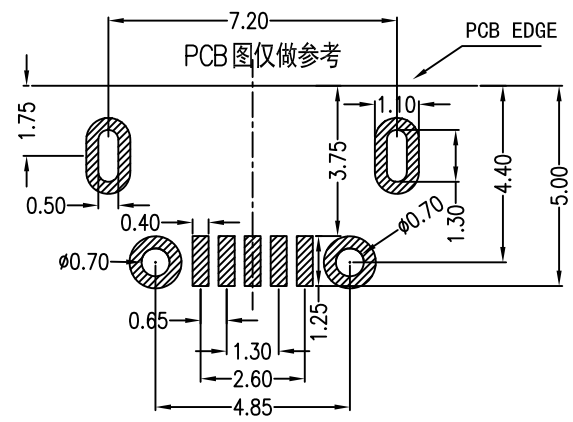
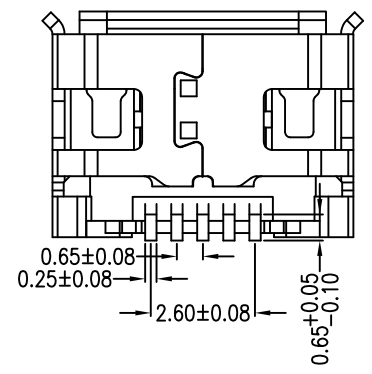
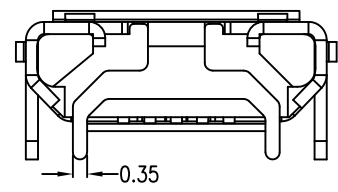
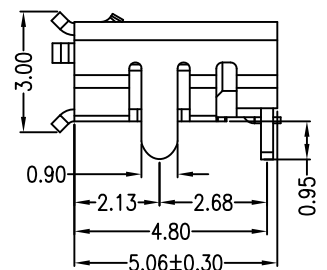
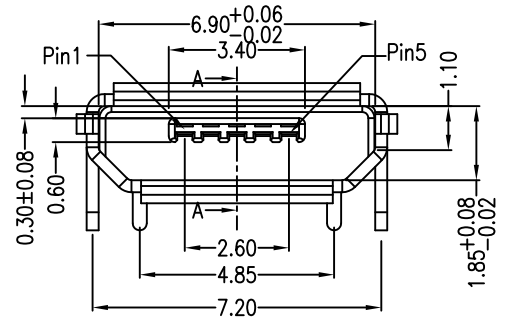
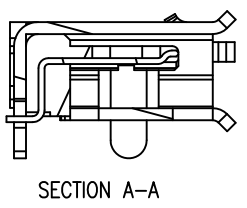
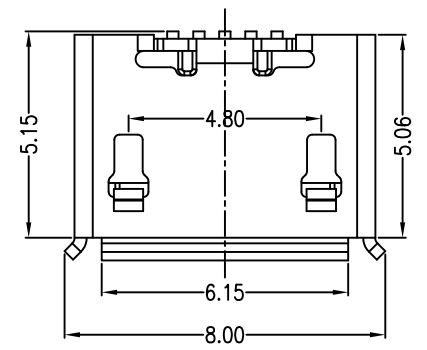
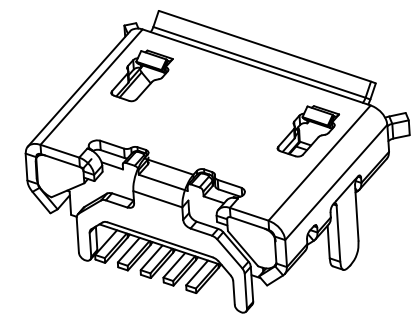

Note:

1.Material:

- 1.1 Housing: High temperature thermoplastic with g.f,UL94v-0
- 1.2 Contact: copper alloy,t=0.15mm
- 1.3 Shell: copper alloy or sus,t=0.30mm

2.Specification:

- 2.1 Current rating:1,5PIN 1.8A Max/2,3,4PIN 1A Max.
- 2.2 Dielectric withstanding voltage: 100 V(ac) for 1 min.
- 2.3 Contact resistance: 30 mΩ Max.
- 2.4 Insulation resistance: 100 MΩ Min.
- 2.5 Total mating force: 3.57 Kgf Max.
- 2.6 Total unmating force: 1.0 Kgf Min.
- 2.7 Temperature range: -30°C~80°C

PIN	定义
1	VBUS
2	D-
3	D+
4	ID
5	GND

产品图			
PRODUCT CHART DWG			
公差一览表			
TOLERANCE UNLESS OTHERWISE			
X.	±0.35	X.	±5°
.X	±0.30	.X	±2°
.XX	±0.20	.XX	±1°
.XXX	±0.10	.XXX	±0.5°

易芯精密科技(浙江)有限公司 Easychips Precision Technology (Zhejiang) Co., Ltd.			
单位	MM	制图	制图料号
UNITS	MM	DRAWING	PRODUCT PART NO
比例	1:1	审核	产品名称
SCALE	1:1	CHKD	MICRO/5P-F B型7.2/4.85四牛角型有卷边
日期	2016-09-09	核准	产品图号
DATE	2016-09-09	APPD	无柱SMT短针黑胶
			角法
			VIEW
			版本
			VER
			AD