

MAPX	MODIFICATION	DATE
------	--------------	------

- Note:
- Material:
 - Housing: High temperature thermoplastic with g.f,UL94v-0
 - Contact: copper alloy,t=0.15mm
 - Shell: copper alloy or SUS,t=0.25mm
 - Specification:
 - Current rating:1,5PIN 1.8A Max/2,3,4PIN 1A Max.
 - Dielectric withstanding voltage: 100 V(ac) for 1 min.
 - Contact resistance: 30 mΩ Max.
 - Insulation resistance: 100 MΩ Min.
 - Total mating force: 3.57 Kgf Max.
 - Total unmating force: 1.0 Kgf Min.
 - Temperature range: -30°C~80°C

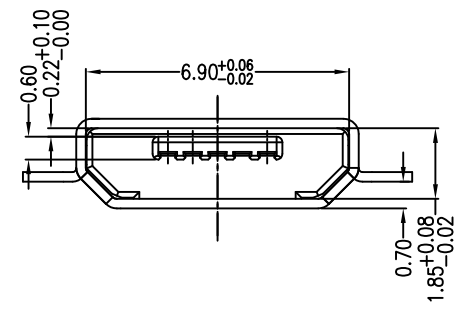
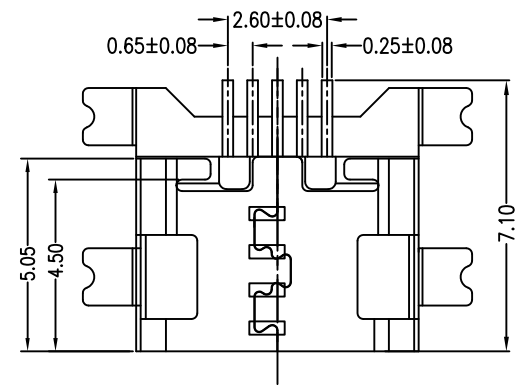
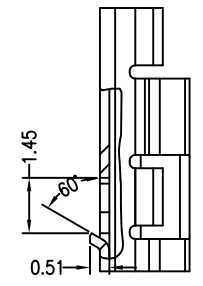
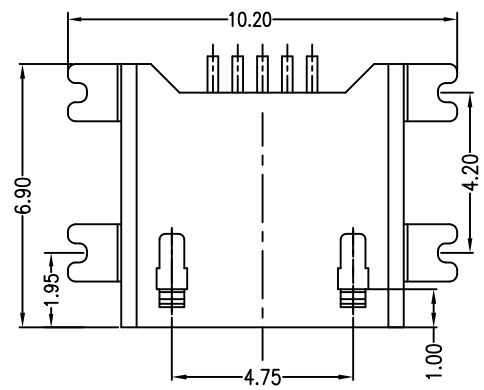
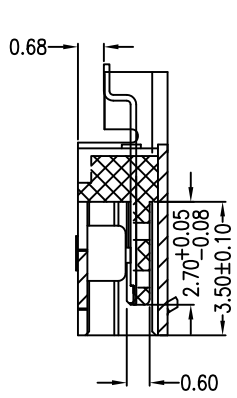
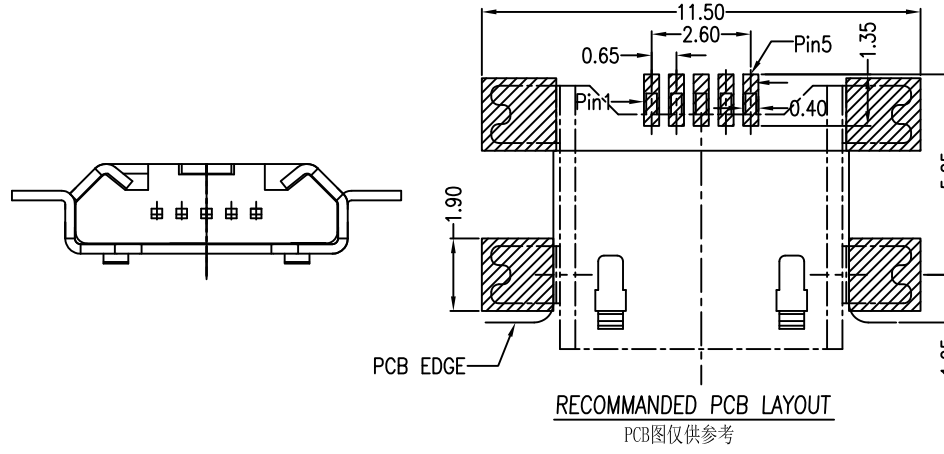

产品图 PRODUCT CHART DWG				易芯精密科技(浙江)有限公司 Easychips Precision Technology (Zhejiang) Co., Ltd.			
公差一览表				单位	MM	制图	制图料号
TOLERANCE UNLESS OTHERWISE				UNITS		DRAWING	PRODUCT PART NO
X.	±0.30	X.	±5.°	比例	1:1	审核	B920-ECF62A2021S10102
.X	±0.25	.X	±2.°	SCALE		CHKD	产品名称
.XX	±0.15	.XX	±1.°	日期	2021-04-16	核淮	MICRO 5S 沉板式0.7四脚全贴无边LCP
.XXX	±0.10	.XXX	±0.5°	DATE		APPD	黑胶
				角法	核淮	APPD	版本
				VIEW			VER
							AD