

REV	DESCRIPTION	DESIGN	DATE
A0	Release		2015.07.01

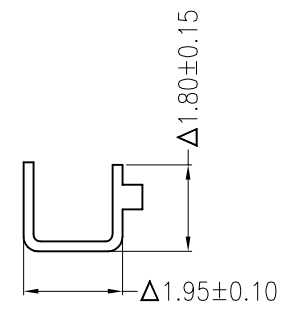

A-A

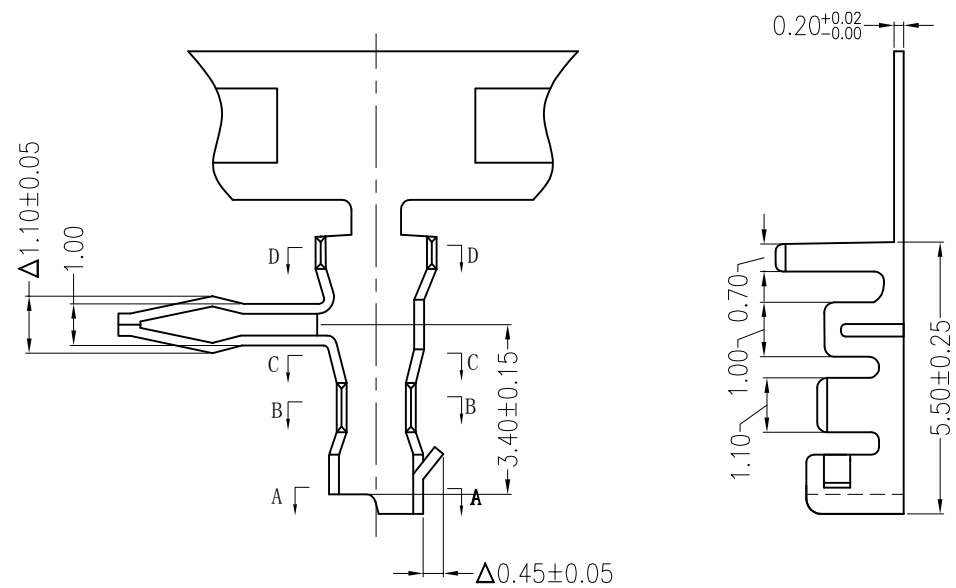
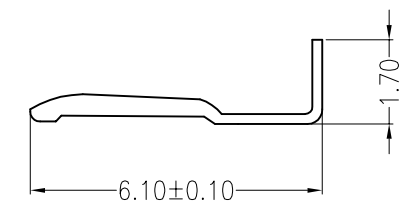

C-C

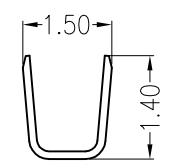

B-B

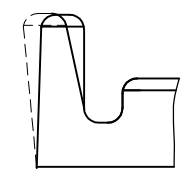

图C

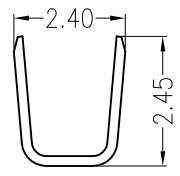

D-D

Ordering Information & Specification:

Part No	Wire Range	Insulation O.D.	Material	Finish	Qty/Reel
EC-B-2502-BB	AWG #22~#28	1.80mm(max)	Phosphor bronze	Sn-plated	10,000 pcs

		易芯精密科技(浙江)有限公司 Easychips Precision Technology (Zhejiang) Co., Ltd.		TITLE:	
X.±0.5	X.±5'	USE:	CUSTOMER		
.X±0.3	.X±2'		APPD:	PART NO.: EC-B-2502-BB	
.XX±0.25	.XX±1'	CHKD:	DWG NO.:		
--	--	DR:	SCALE	SHEET	
		UNITS: mm	1 : 1	1 / 1	