

REV	DESCRIPTION	DESIGN	DATE
A0	Release	吴丹平	2017.10.12

TYPE-Poles	Dimensions (mm)	
	DIM=A	DIM=B
A7501A-1P	—	6.00
A7501A-2P	7.50	12.50
A7501A-3P	12.50	17.50
A7501A-4P	17.50	22.50
A7501A-5P	22.50	27.50
A7501A-6P	27.50	32.50

主要技术参数 Main Specifications

线 数 (Poles): 01 to 06
 接触电阻 (Contact resistance): $\leq 10m\Omega$
 绝缘电阻 (Insulation resistance): $\geq 1000M\Omega$
 额定电压 (Rated voltage): 250V AC DC
 额定电流 (Rated current): 5.0A AC DC
 耐 电 压 (Withstand Voltage): 1500V AC/minute
 温度范围 (Temperature Range): $-25^{\circ}C \sim +85^{\circ}C$

ORDER INFORMATION:

A7501A--A5WA-P**

PART No.:		PACKAGING:	P=PE
No. OF CIRCUITS:	01~06	PLATING:	A=Sn
PLASTIC MATERIAL:	A5W=PA66 (WHITE)		

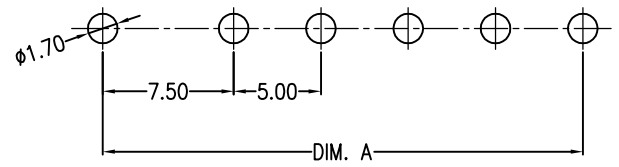
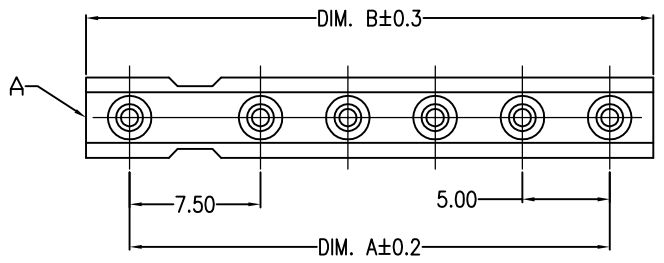
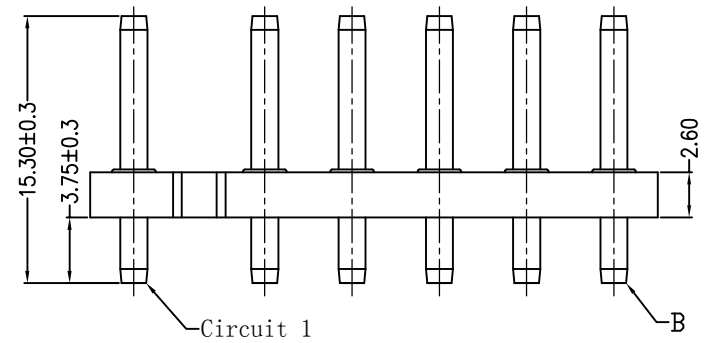
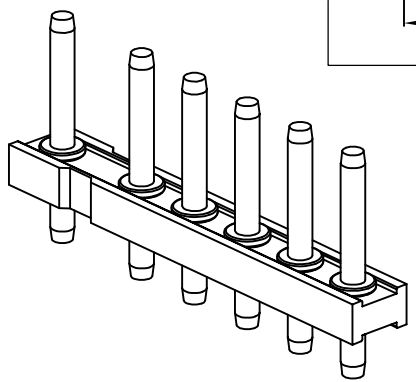
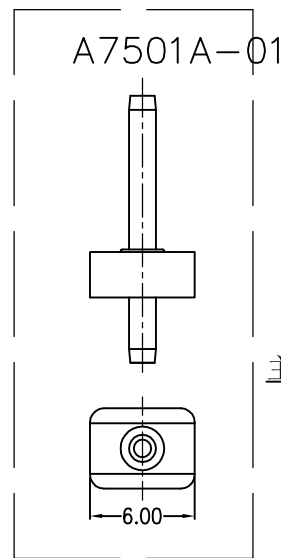

SUGGESTED PCB LAYOUT
(COMPONENT SIDE)

C				
B	CONTACT	1~6 PCS	Brass	Sn-plated
A	PEDESTAL	1 PCS	PA66	COLOR:WHITE
ITEM	COMPONENT	Q'TY	MATERIAL	FINISH

			TITLE: -	
易芯精密科技(浙江)有限公司 Easychips Precision Technology (Zhejiang) Co.,Ltd.			7.5/5.0mmPITCH 180°WAFER	
X.±0.5	X.±5'	USE:	PART NO.:	
.X±0.3	.X±2'	CUSTOMER	ECA750106	
.XX±0.25	.XX±1'	APPD:	DWG NO.:	
--	--	CHKD:	JKUN/GCCP-0634	
⊕	UNITS: mm	DR:	SCALE	SHEET
			1 : 1	1 / 1