

电气原理图

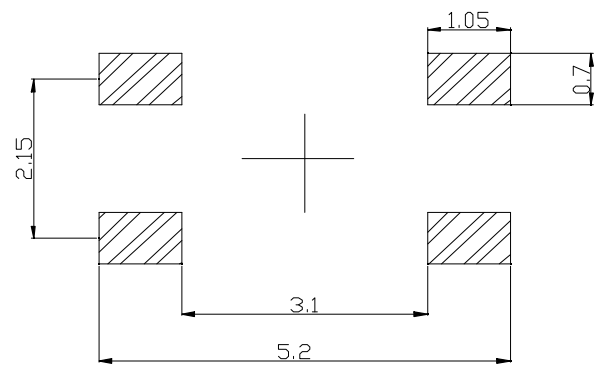

P.C.B 板焊接图

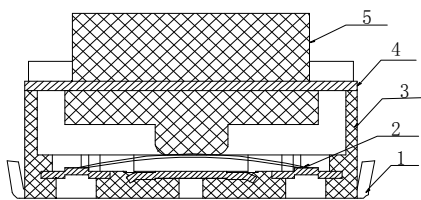

技术要求

1. 塑料件表面光洁无划痕，水花，变形，影响外观及性能等缺陷。
2. 额定电流：50mA. 12V DC, 绝缘电阻100M Ω min. 100V DC. 介电强度250V AC for 1min. 接触电阻100m Ω max.
3. 开关手感明显，档位清晰可靠，无卡滞现象，消除外力后，应能快速回位。

序号	零部件名称	数量	材料名称	表面处理	备注
1	端子	1	黄铜	银镀层	
2	弹片	1	SUS301	银镀层	
3	基座	1	LCP		
4	盖板	1	不锈钢		
5	推柄	1	PPA		白色
设计:  易芯精密科技(浙江)有限公司					
审核:  Easychips Precision Technology (Zhejiang) Co., Ltd.					
批准:  单位: mm 比例: 1/1 日期:					
轻触开关				页次: 1/1	版本: 0
型号: ECTVBU17-025CW-R			图纸名称: 产品外形图		